

**D****Wichtige Pflegehinweise**

Bitte beachten Sie die wichtigen Pflegehinweise auf unserer Internetseite



www.held-hilft.de



Pflegehinweise

**PL****Ważne instrukcje dotyczące pielęgnacji**

Zwróć uwagę na ważną instrukcję dotyczącą pielęgnacji na naszej stronie internetowej



www.held-hilft.de



Pflegehinweise

**GB****Important care instructions**

Please note the important care instructions on our website



www.held-hilft.de



Pflegehinweise

**SK****Dôležité pokyny na starostlivosť**

Dbajte na dôležité pokyny týkajúce sa starostlivosti na našich webových stránkach



www.held-hilft.de



Pflegehinweise

**FR****Instructions d'entretien importantes**

S'il vous plaît noter les instructions de soins importants sur notre site Web



www.held-hilft.de



Pflegehinweise

**HU****Fontos kezelési utasítások**

Kérjük, vegye figyelembe a honlapunkon található fontos kezelési útmutatót



www.held-hilft.de



Pflegehinweise

**IT****Importanti istruzioni per la cura**

Si prega di notare le importanti istruzioni per la cura sul nostro sito web



www.held-hilft.de



Pflegehinweise

**RO****Instrucțiunile importante de îngrijire**

Rețineți instrucțiunile importante de îngrijire de pe site-ul nostru



www.held-hilft.de



Pflegehinweise

**NL****Belangrijke zorginstructies**

Let op de belangrijke zorginstructies op onze website



www.held-hilft.de



Pflegehinweise

**TR****Önemli bakım talimatları**

Lütfen web sitemizdeki önemli bakım talimatlarını dikkate alınız



www.held-hilft.de



Pflegehinweise

**CZ****Důležité pokyny pro péči**

Vezměte prosím na vědomí důležité pokyny pro péči na našich webových stránkách



www.held-hilft.de



Pflegehinweise

**RU****Важные инструкции по уходу**

Обратите внимание на важные инструкции по уходу на нашем веб-сайте



www.held-hilft.de



Pflegehinweise





Wir sind für Sie da!

Schnelle Hilfe 24/7
www.held-hilft.de

Ersatzteil-Sofort-Hilfe:
0571-7983810

21-08-2018

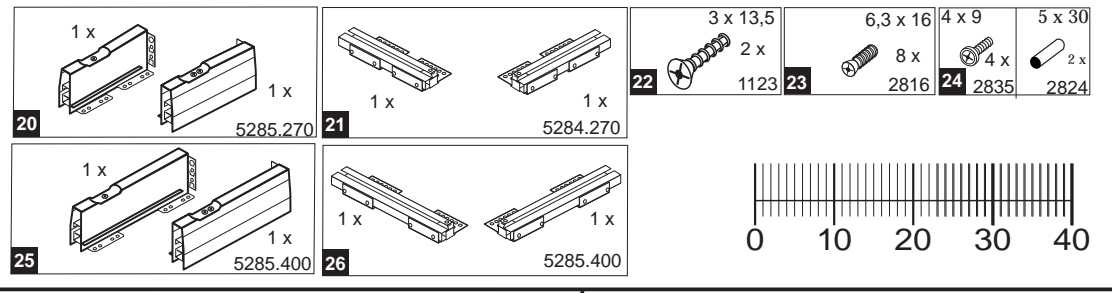
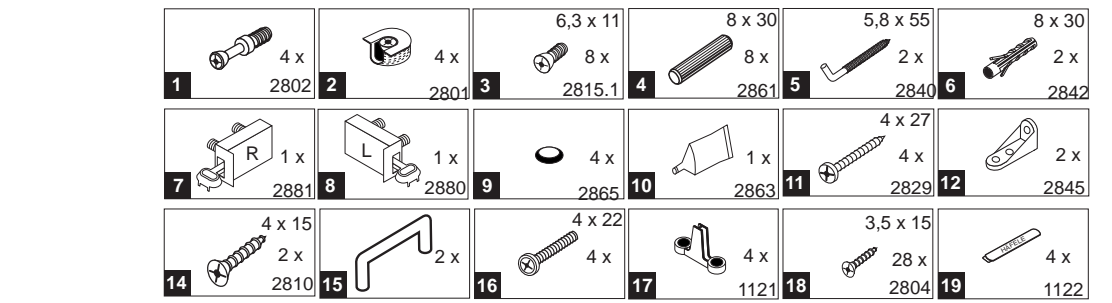
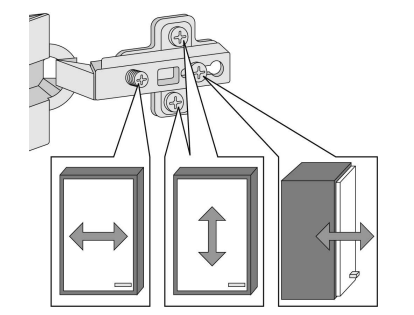
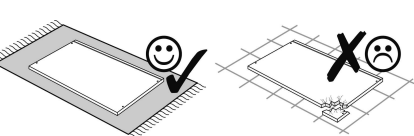
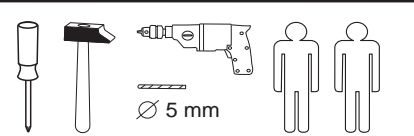

Das beigegefügte Wandbefestigungsmaterial (Dübel und Schrauben) eignet sich nur für festes Mauerwerk (z.B.: Beton- oder Ziegelwände). Für andere Wandaufbauten sind eventuell Spezialdübel und andere Schrauben notwendig. Ziehen Sie gegebenenfalls eine Fachkraft zu Rate.

De begeleidende wandmontage hardware (pluggen en schroeven) is alleen geschikt voor massief metselwerk (bijvoorbeeld beton of bakstenen muren). Voor andere muur structuren zijn eventueel bijzondere ankerbouten en andere noodzakelijke. Draai indien nodig, een deskundige.

Приложенный материал для крепления к стене (дюбели и винты) пригоден только для жестких кладок (например бетонные или кирпичные стены). Для других настенных конструкций необходимы смотря по обстоятельствам специальные дюбели и другие винты. При необходимости проконсультируйтесь у специалиста.

Le mur d'accompagnement matériel de montage (chevilles et les vis) ne convient que pour la maçonnerie solide (par exemple en béton ou des murs de briques). Pour les structures de mur d'autres sont peut-etre spéciale boulons d'ancrage et d'autres nécessaires. Serrer le cas échéant, un expert.

Załączony materiał do mocowania do ściany (kolki rozprężne i wkręty) nadaje się tylko do ścian murowanych (np. z betonu lub cegieł). Do ścian wykonanych w innych technologiach konieczne być mogą specjalne kolki rozprężne i inne wkręty. W razie potrzeby skorzystaj z fachowej pomocy.

Il muro di accompagnamento hardware di montaggio (tasselli e viti) è adatto solo per muratura piena (ad esempio calcestruzzo o muratura). Per le altre strutture murarie sono forse speciali bulloni di ancoraggio e necessari di altri. Serrare se necessario, un esperto.

The accompanying wall mounting hardware (anchors and screws) is suitable only for solid masonry (eg concrete or brick walls). For other wall structures are possibly special anchor bolts and other necessary. Tighten if necessary, an expert.

Ekteki duvara sabit montaj malzemeleri (dübel ve vidalar), sadece sağlam duvarlar için (örnek: beton veya tuğla) elverişlidir. Başka duvarlar için özel dübeller ve farklı vidalar gerekebilir. Gerektiğinde bir bilene danışınız.

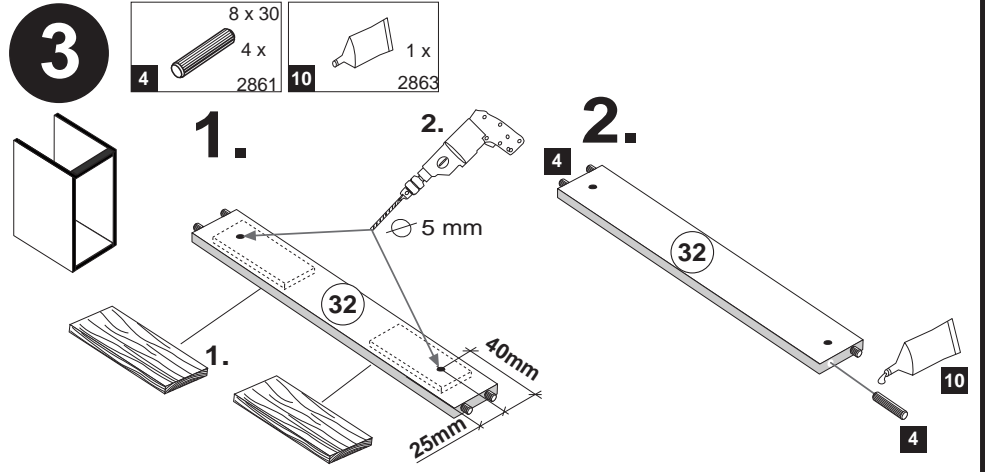
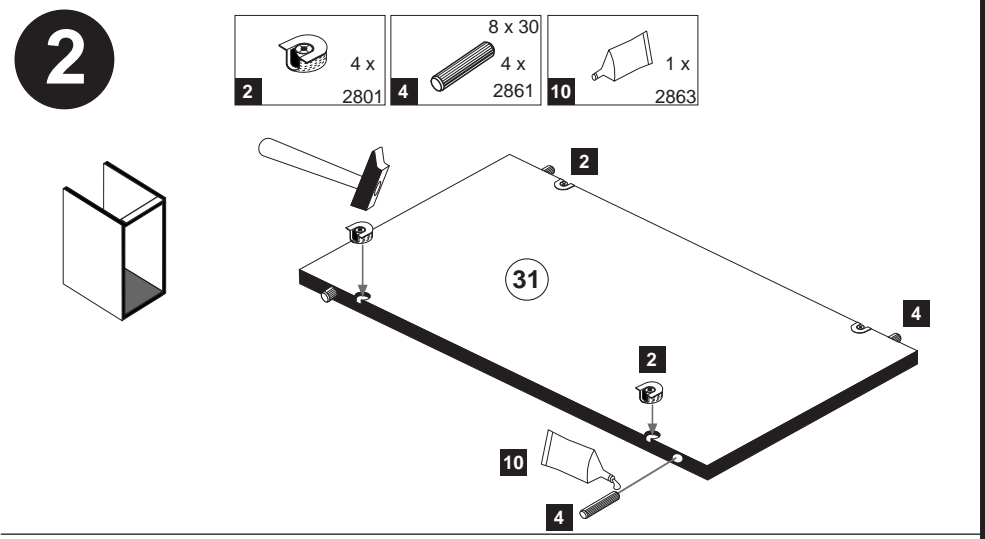
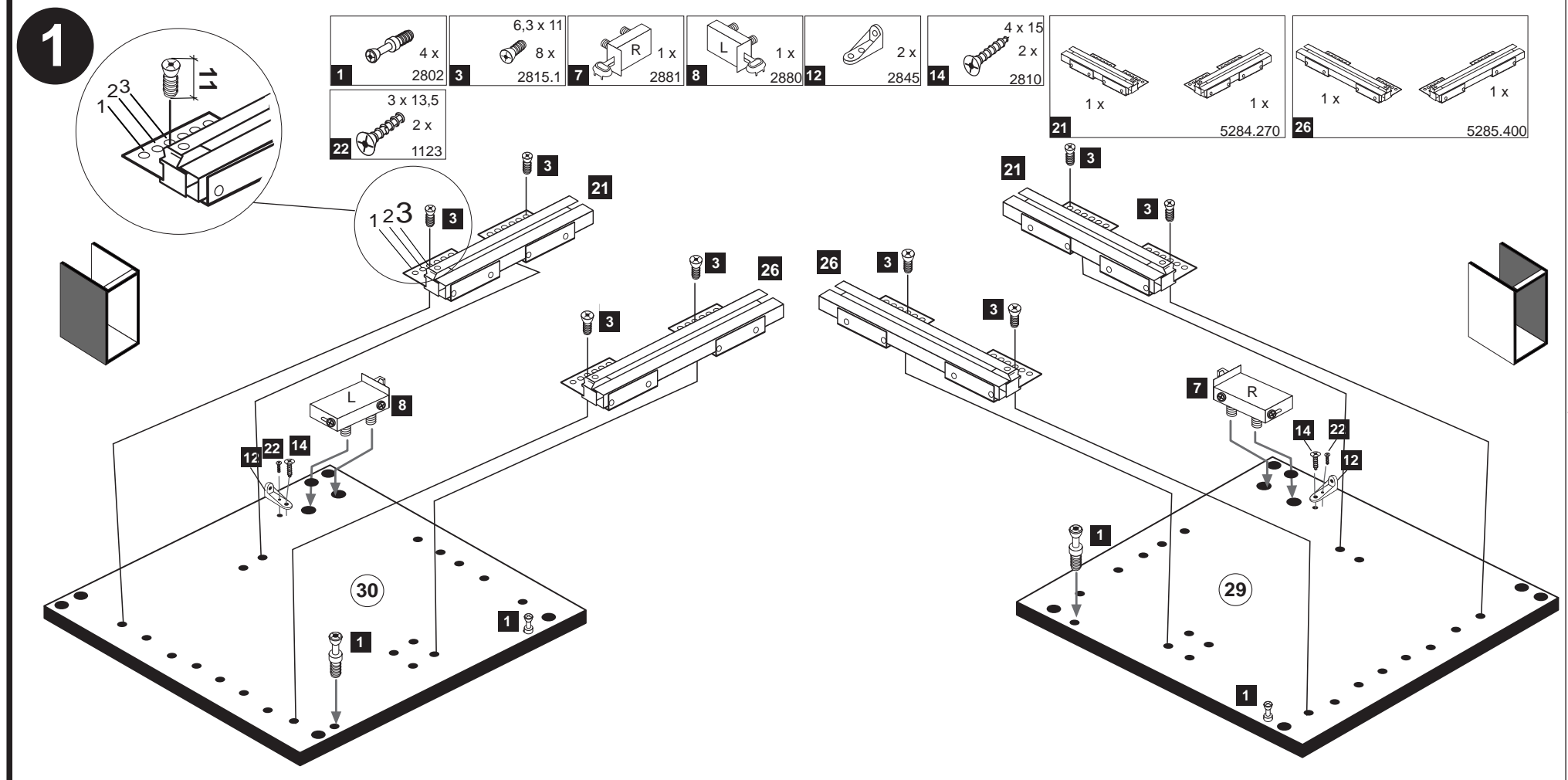
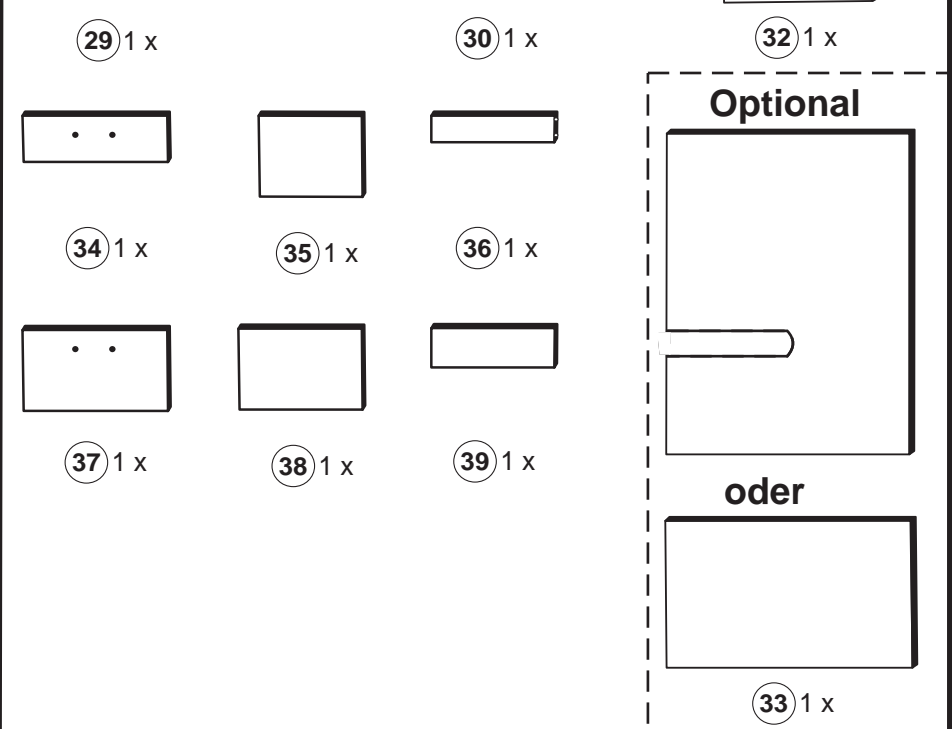
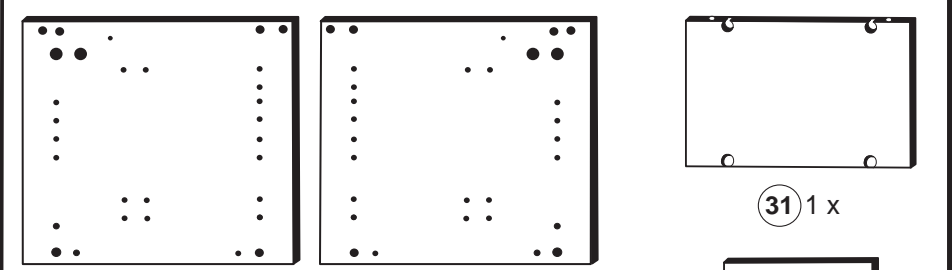

4

10 20 min.

1 x 2863

D Leim
GB Glue
NL Lijm
PL Klej
TR Tutkal
F Colle
I Colla

9 2x 2865

15 1x

16 4 x 22 2x

17 2x 1121

23 6,3 x 16 4x 2816

30 29 31 32

6

1. 2. \varnothing 5 mm

9 34

1. 16 23 17 15

34 16 17 23

8

35 36 20

9

18 3,5 x 15 4 x 2804

18 36 35 20

5

11 4 x 27 4 x 2829

33 11

7

18 3,5 x 15 8 x 2804

21 1x 5284.270 1x

18 35 20

Wichtig!
Montieren Sie den Boden an der Vorderkante bündig mit der Zarge 20!

10

19 2 x 1122

Klick!

HÄFELE 36 35 20 34 17

11

9 2x 2865	15 1x 6,3 x 16	16 4 x 22 2 x
17 2x 1121	23 4 x 2816	

1. $\varnothing 5\text{ mm}$

2.

13

16

4 x 9 4 x 24 2835	5 x 30 2 x 2824
-------------------------	-----------------------

Verbindungsvariante

1. $\varnothing 5\text{ mm}$
4 x

2. $\varnothing 5\text{ mm}$
4 x

14

18 3,5 x 15 4 x 2804	18
-------------------------------	----

Hinweis !
 Wie Sie den Schubkasten einhängen müssen entnehmen Sie bitte dem beigefügten Montagezettel der Firma HÄFELE.
 Zusätzlich finden Sie auf dem Montagezettel folgende Abbildungen und Montagehilfen:

- Montage der Abdeckkappe
- Einstellen der Schubkastenblende
- Aushängen des Schubkastens
- Abnehmen der Schubkastenblende

12

18 3,5 x 15 8 x 2804	25 1 x 5284.400 1 x
-------------------------------	------------------------------

Wichtig!
 Montieren Sie den Boden an der Vorderkante bündig mit der Zarge 25!

15

19 2 x 1122	19
-------------------	----

Klick!

17

5 5,8 x 55 2 x 2840	6 8 x 30 2 x 2842
------------------------------	----------------------------

4

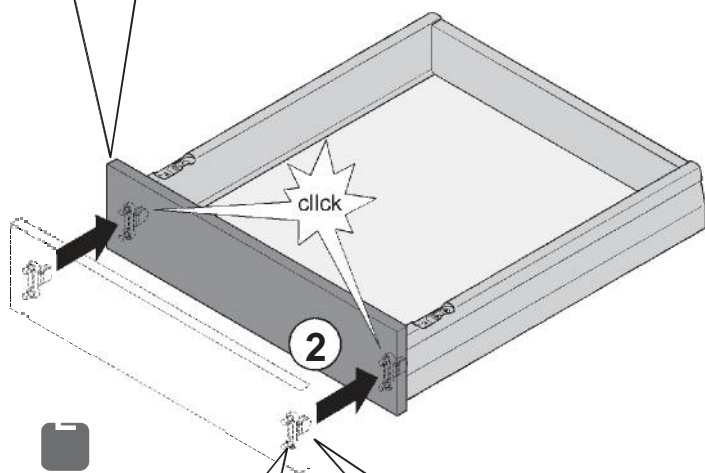
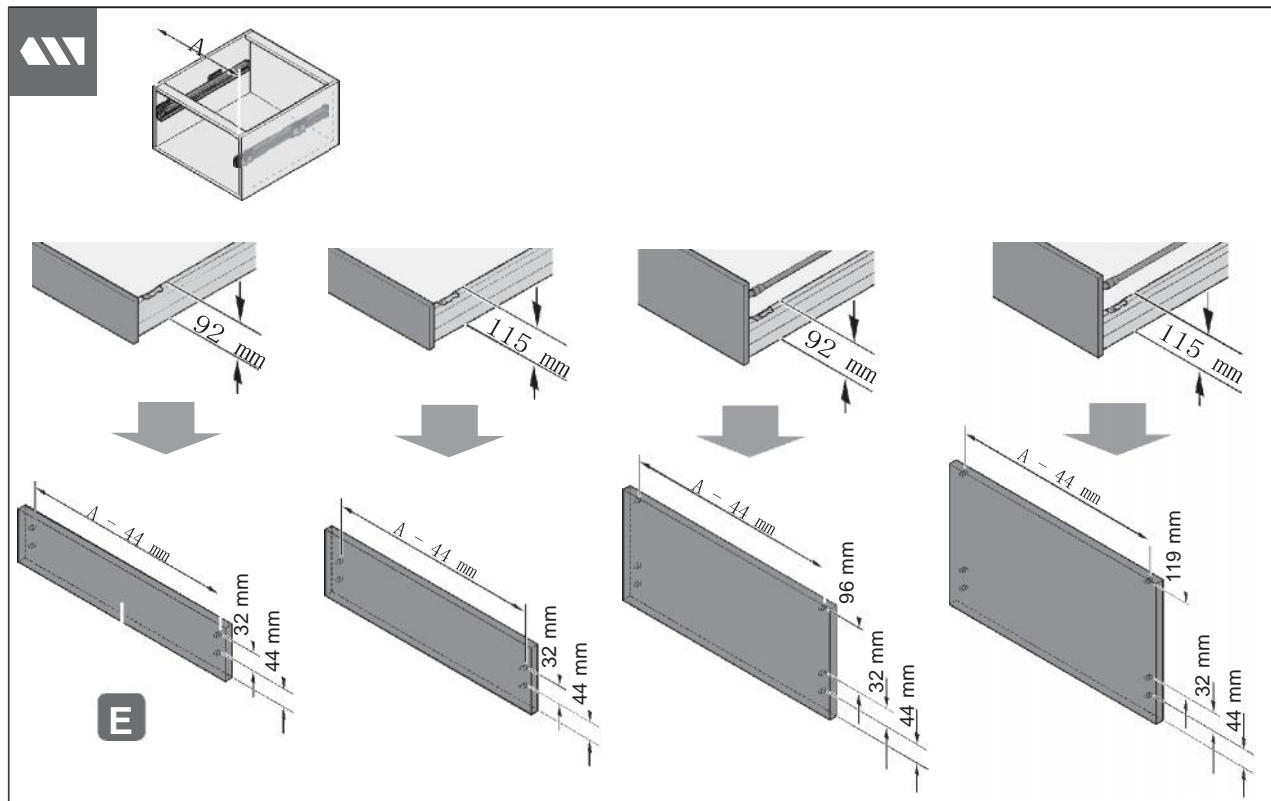

Variante
Version
Versión
Versione

A

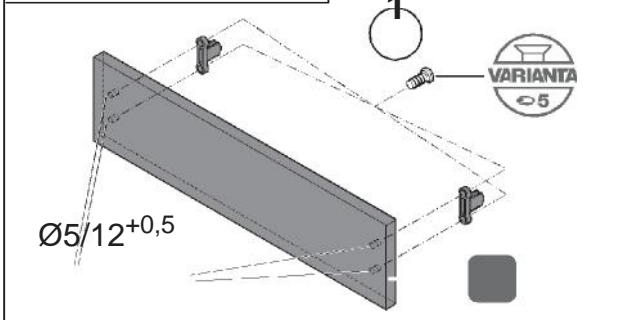

Variante
Version
Versión
Versione

B

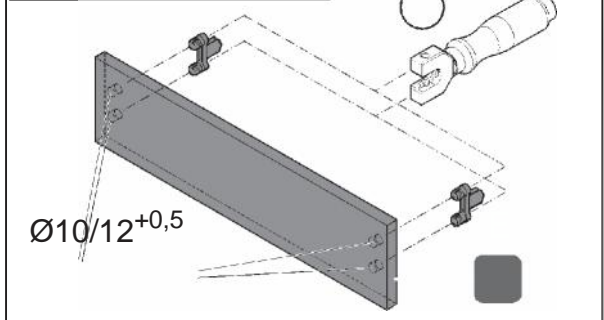

Maße in mm – Dimensions in mm – Medidas en mm – Misure in mm

HDE 10.11.09



5

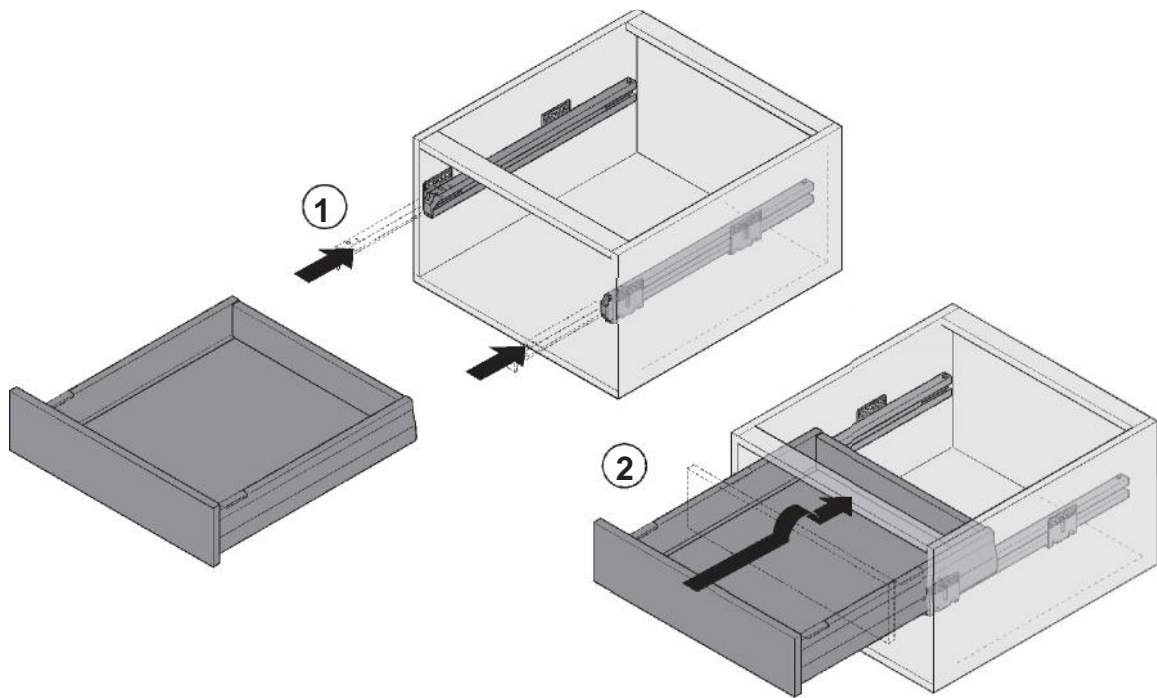

Einstellung

En
Fr
Es
It

HDE 10.11.09 Maße in mm – Dimensions in mm – Medidas en mm – Misure in mm

