

Montageanleitung

Notice de montage

Assembly instruction

GERMANIA®
the furniture factory

Schuhschrank 3260

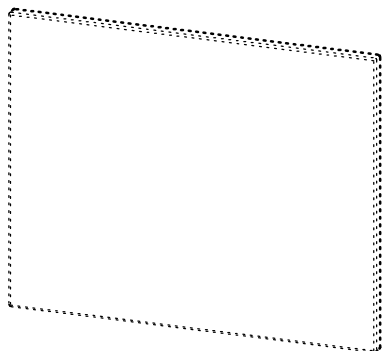

Mod. 3263 2x

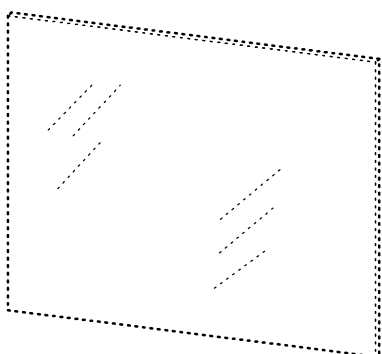

Mod. 3264 2x

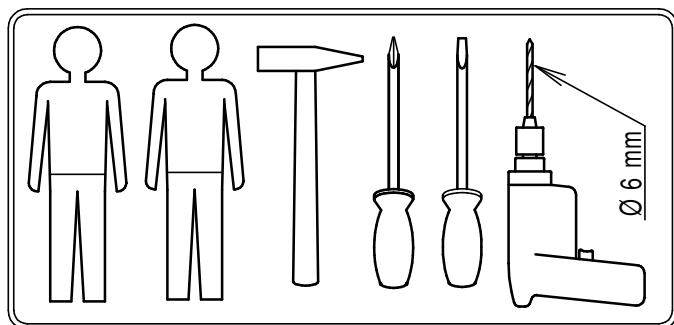
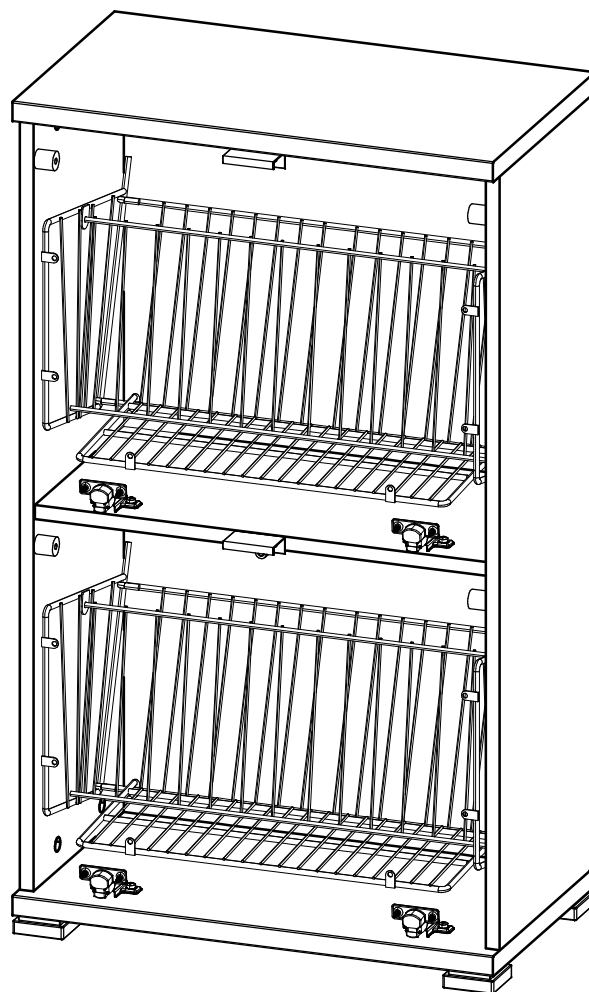

Bitte die Sicherheitshinweise auf der letzten Seite beachten!

Please note: safety instructions on the last page!

Prière de suivre les instructions de sécurité figurant sur la dernière page!

erstellt

geändert









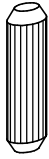
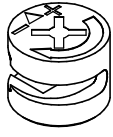
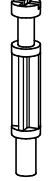
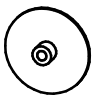
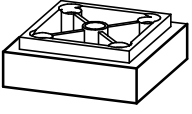
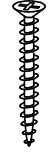

geprüft

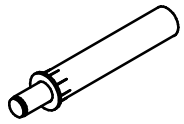
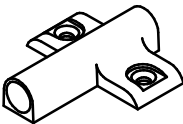
Datum: 06.11.13

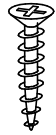
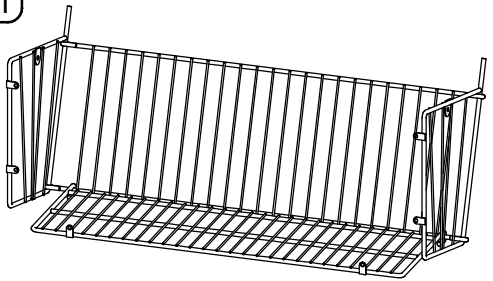
Datum:

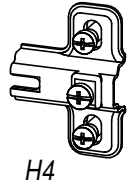
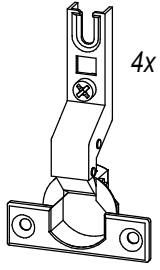
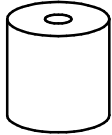
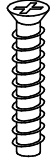
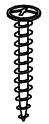
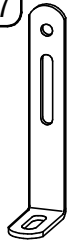
Datum: 11.11.13

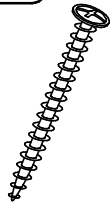
Mod. 3260 Teileliste - liste de pièces - partlist

<p>2218 12x</p>  <p>Ø8 x 30mm</p>	<p>1116 12x</p>  <p>Ø15mm</p>	<p>1114 12x</p>  <p>24 mm</p>	<p>1162 8x</p> 	<p>5403 4x</p>  <p>55x55 mm</p>	<p>1071 8x</p>  <p>Ø4x30mm</p>		
<p>5637 2x</p>  <p>Teilung = 32 mm</p>	<p>1236 8x</p>  <p>Ø6,3x11</p>	<p>4220 2x</p> 	<p>4221 2x</p> 	<p>4095 4x</p> 	<p>1058 4x</p>  <p>Ø3x15mm</p>		
<p>5491 2x</p>  <p>482 x 245 x 260 mm</p>		<p>1238 12x</p>  <p>Ø6,3x13</p>	<p>4840</p>  <p>H4</p> 		<p>5333 4x</p>  <p>Ø20/Ø6,3x20</p>	<p>1416 4x</p>  <p>Ø6,3x30</p>	<p>1267 3x</p>  <p>Ø3x16</p>
<p>1187 1x</p>  <p>90x30x15</p>	<p>1110 1x</p>  <p>Ø6x30mm</p>	<p>1021 1x</p>  <p>Ø4,5x40mm</p>	<p>1042 2x</p>  <p>Ø4x17mm</p>				

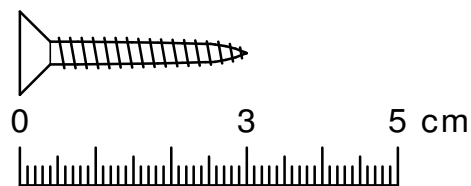

Mod. 3260 **Teileliste** - liste de pièces - partlist

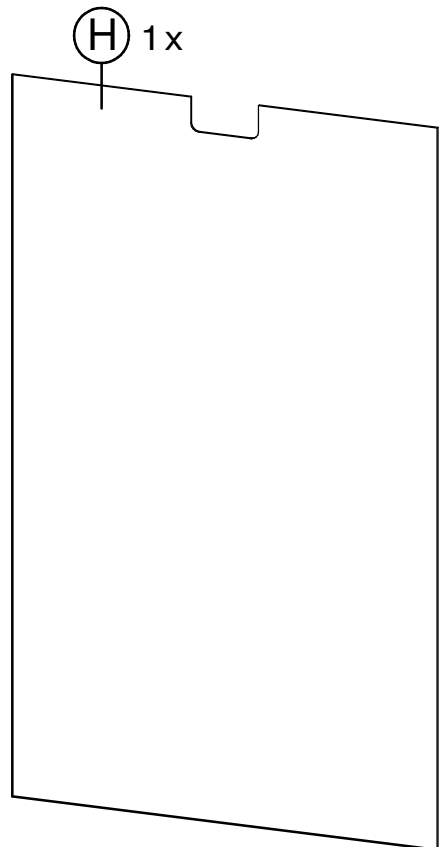
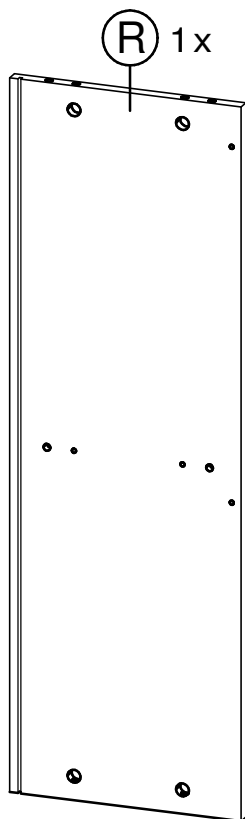
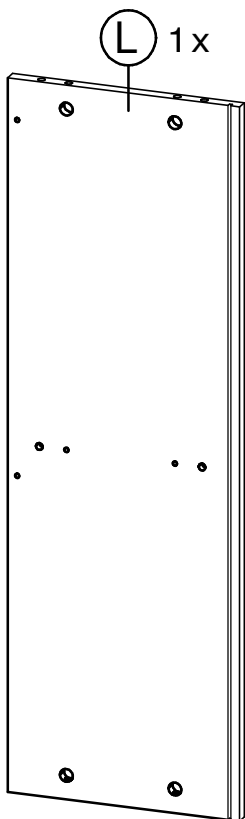
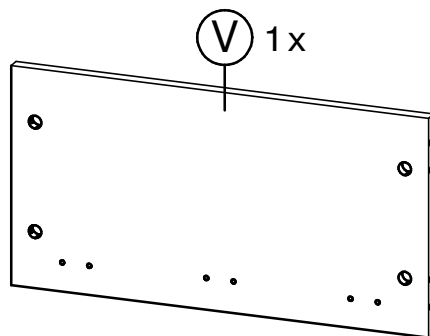
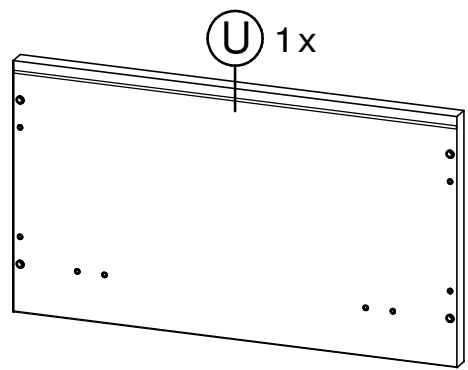
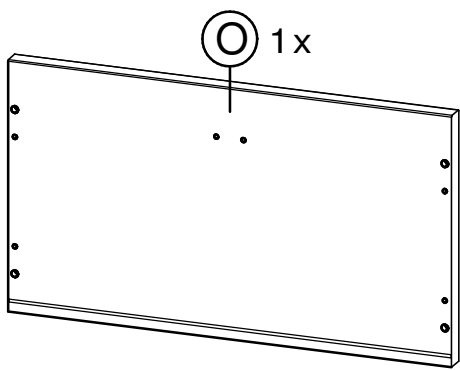

erstellt		geändert		geprüft	
Datum: 06.11.13		Datum:		Datum: 11.11.13	

Mod. 3260 **Montageschritte** - ordre de montage - assembly instructions

1.

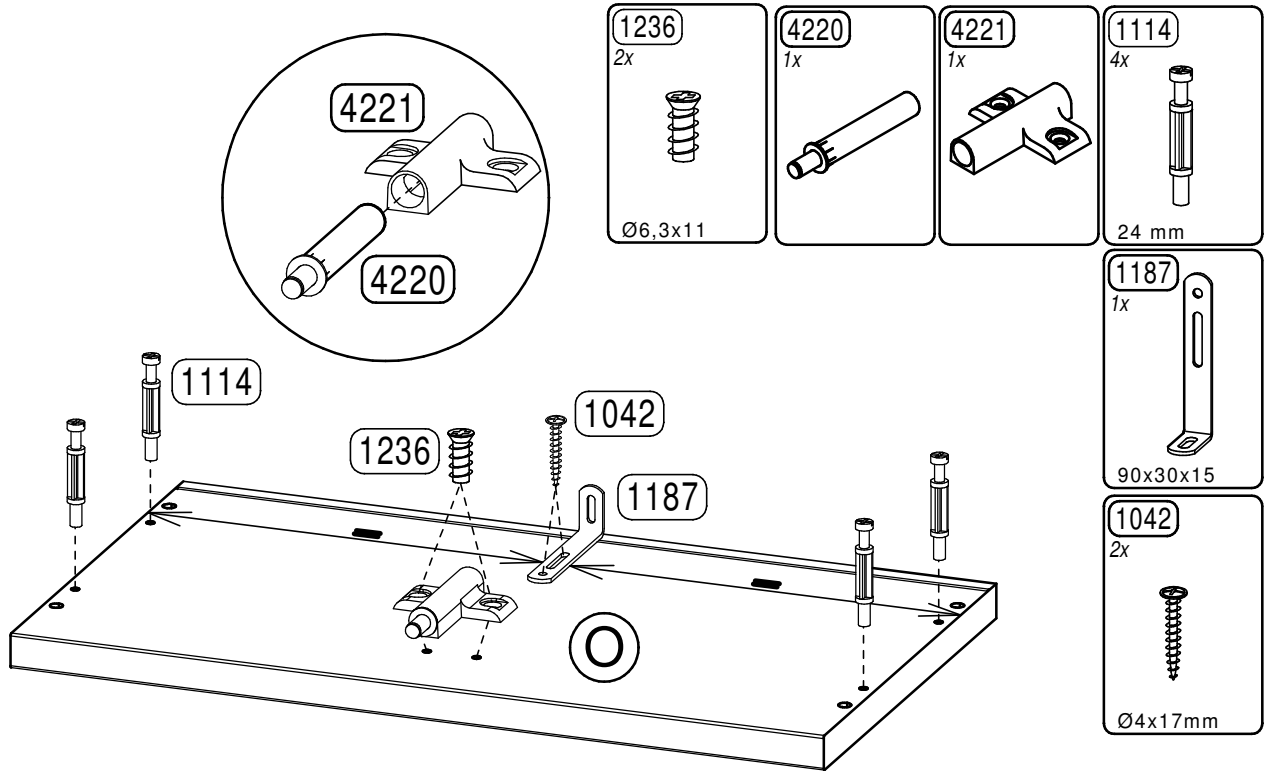

2.

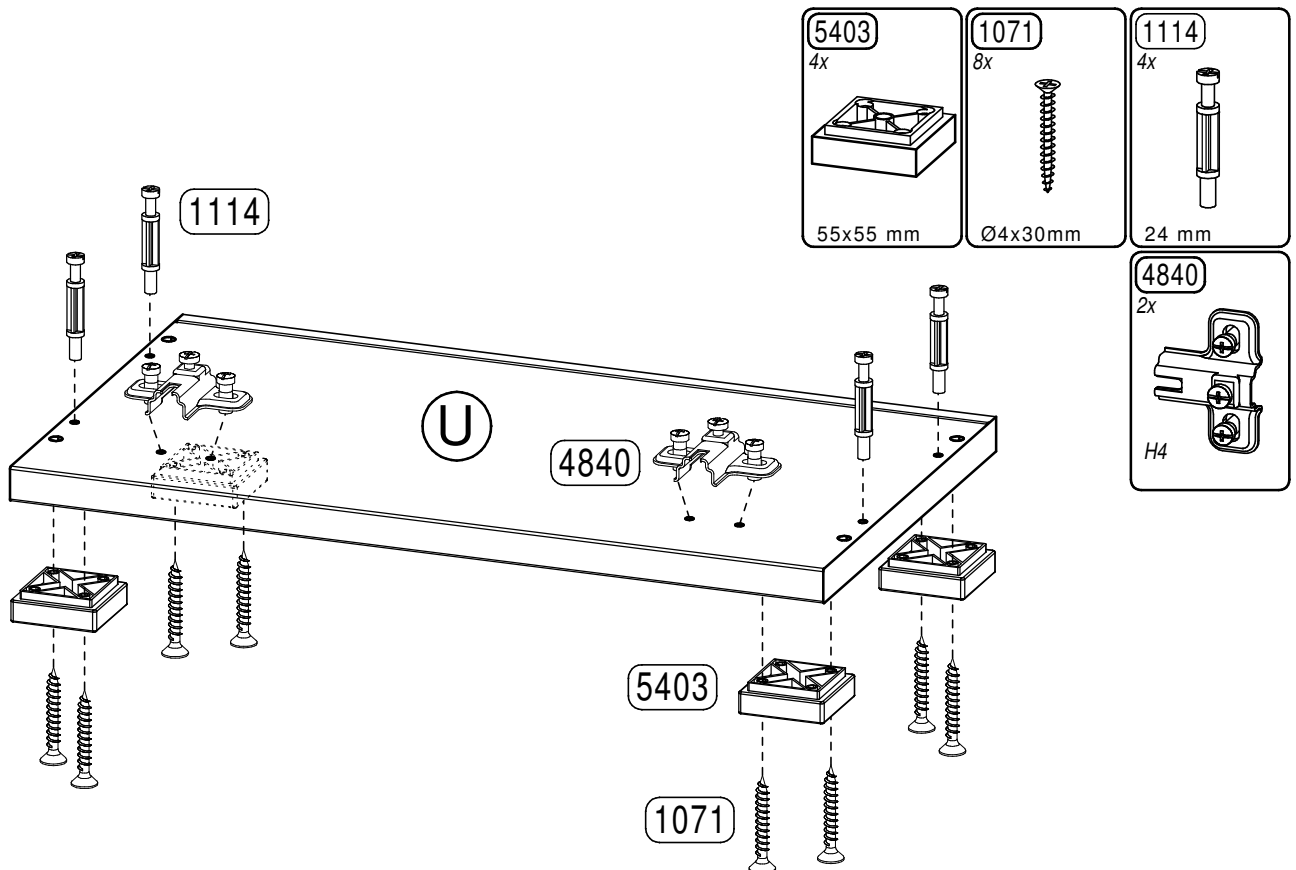

4

erstellt		geändert		geprüft	
Datum: 06.11.13		Datum:		Datum: 11.11.13	

3.

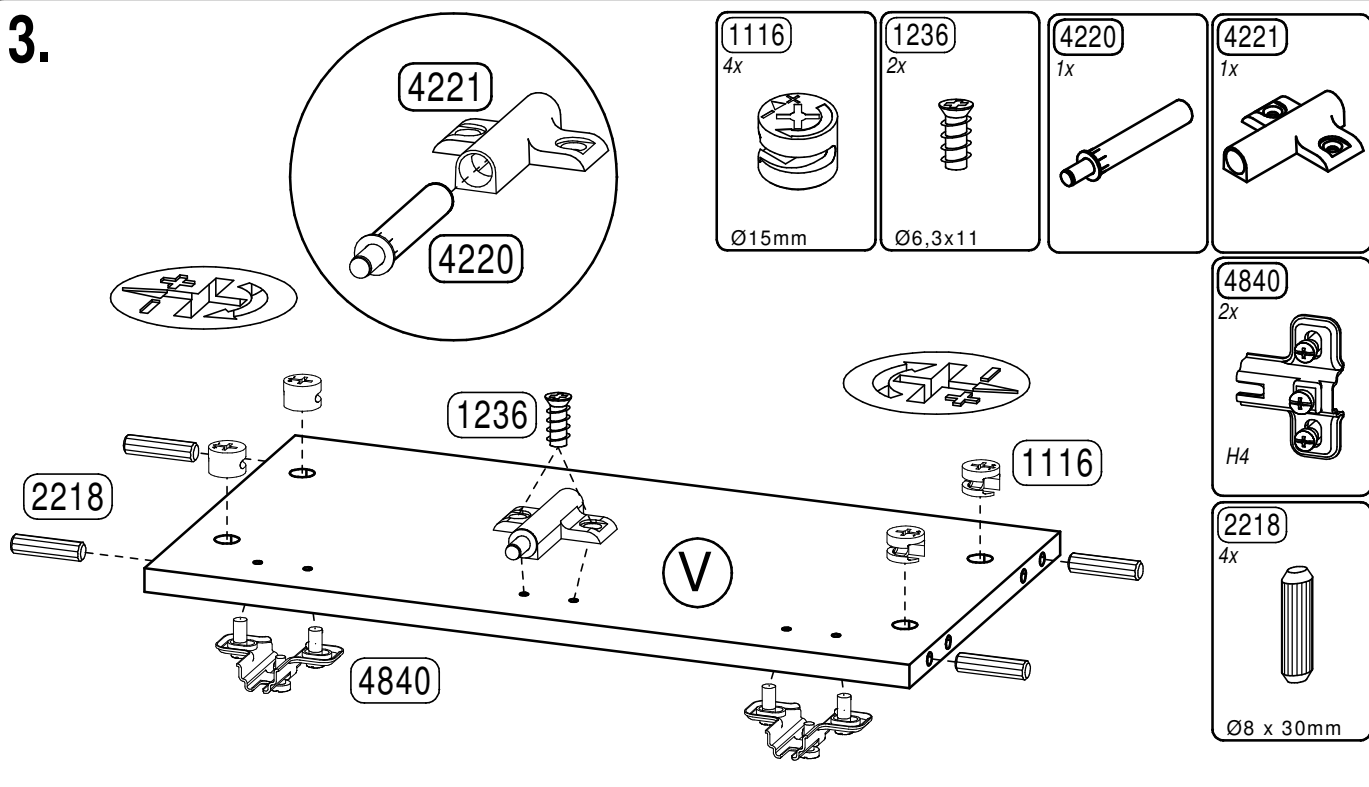

4.

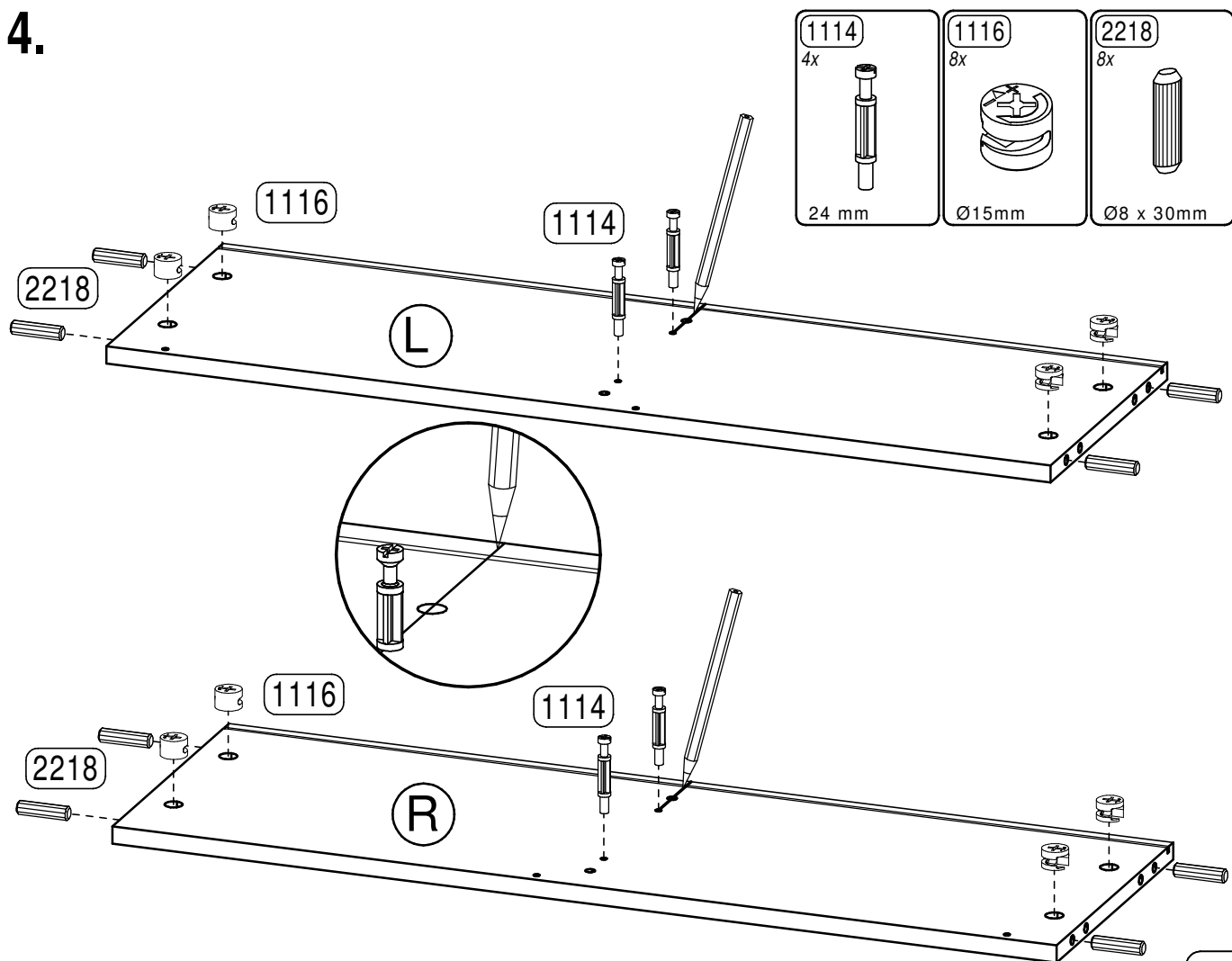

5

erstellt	geändert	geprüft
Datum: 06.11.13	Datum:	Datum: 11.11.13

5.

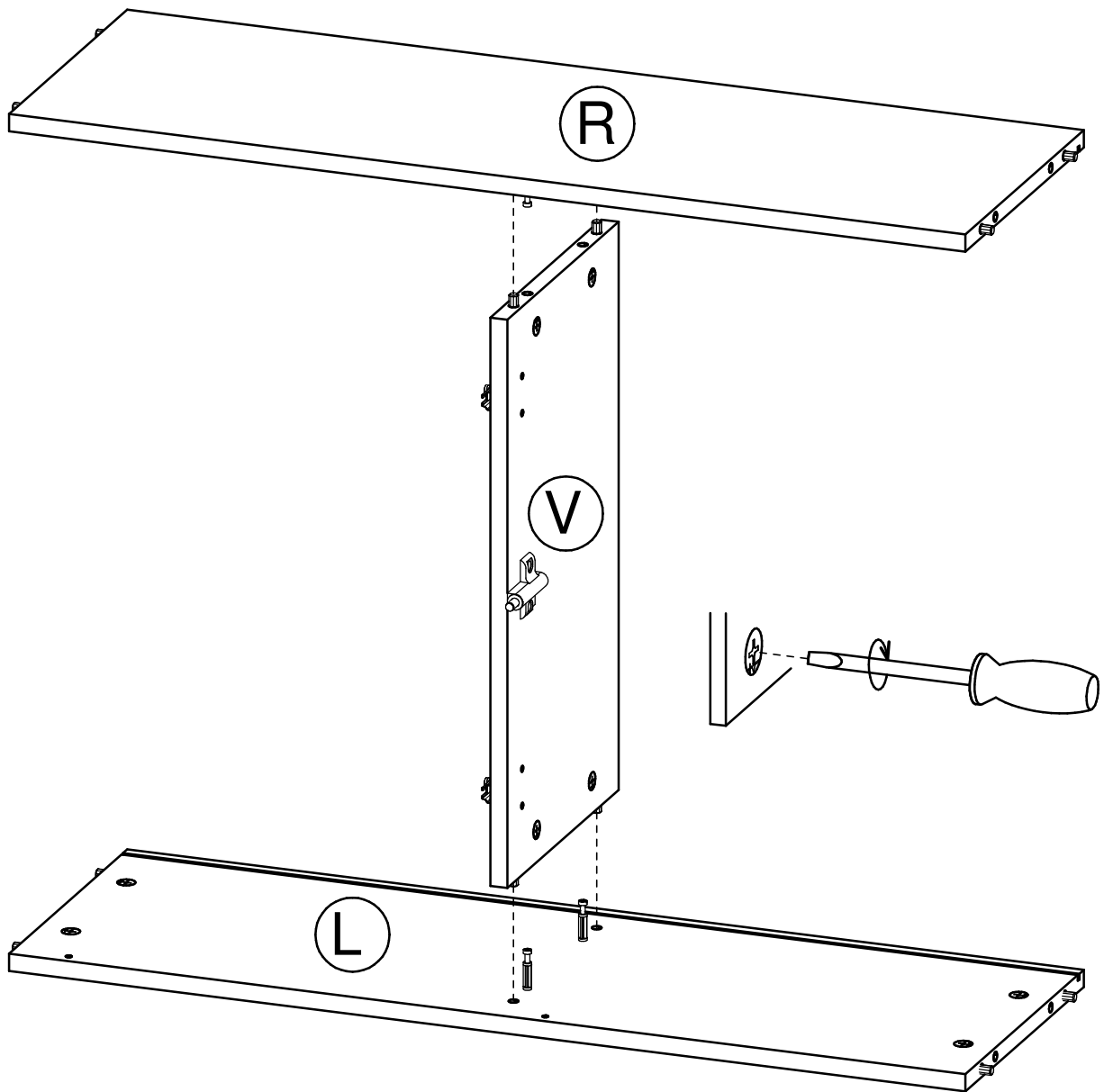

6

erstellt	geändert	geprüft
Datum: 06.11.13	Datum:	Datum: 11.11.13

6.

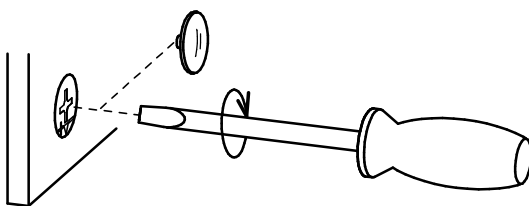
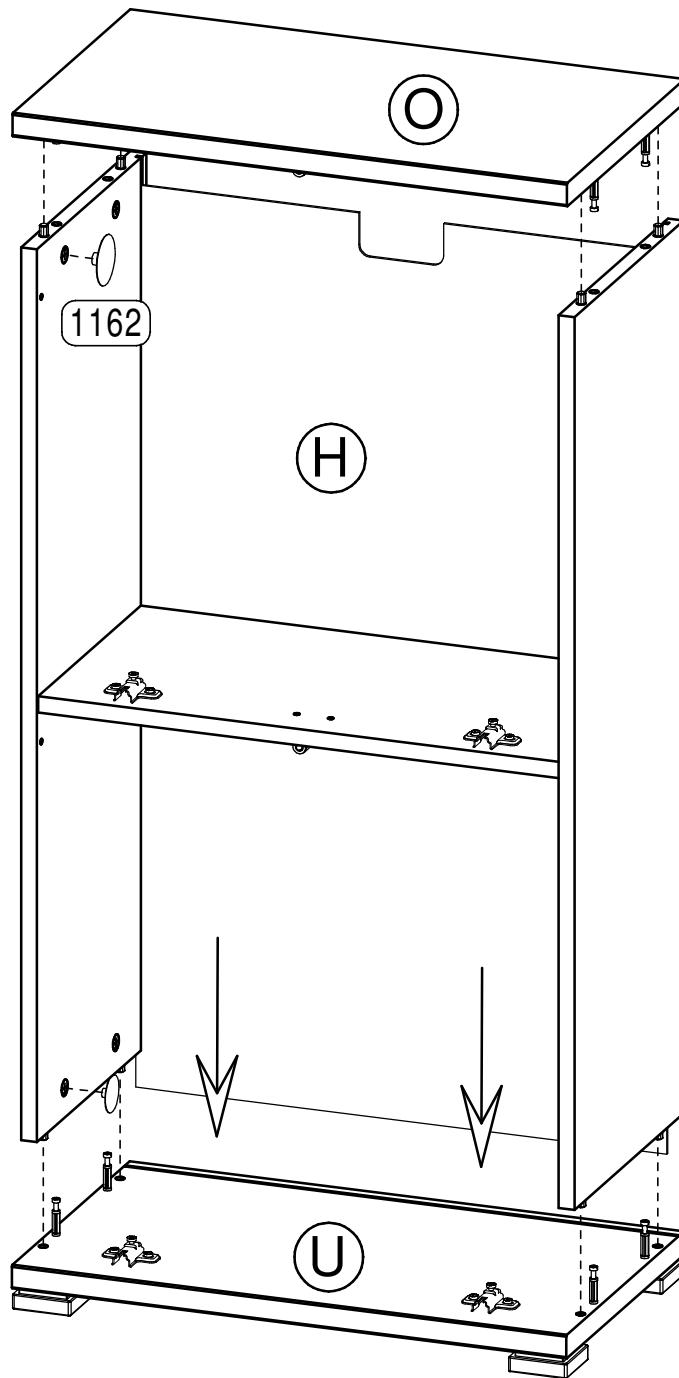
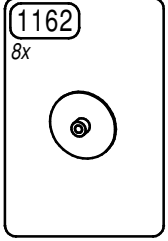

7

erstellt		geändert		geprüft	
Datum: 06.11.13		Datum:		Datum: 11.11.13	

Mod. 3260 **Montageschritte** - ordre de montage - assembly instructions

7.

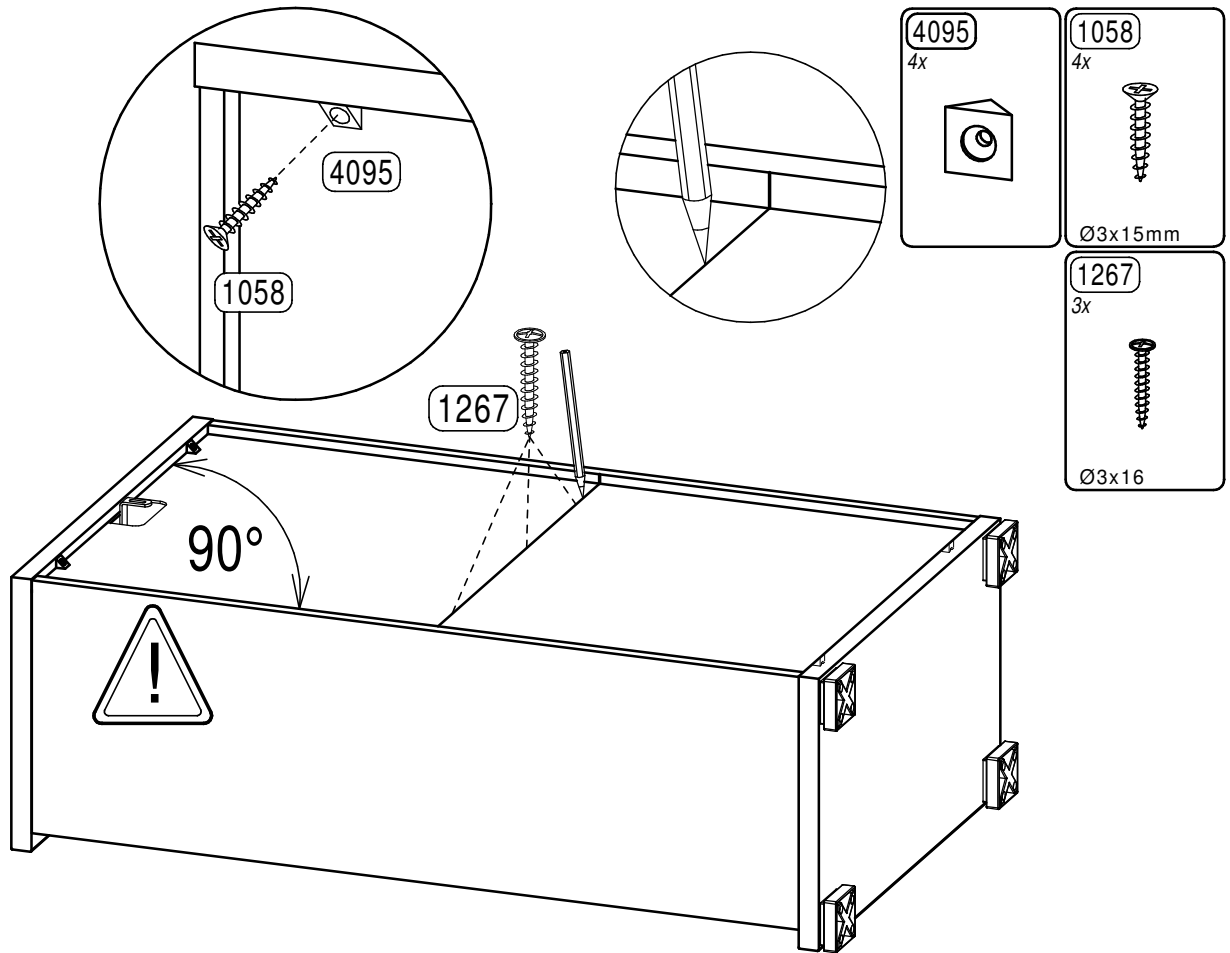

8.

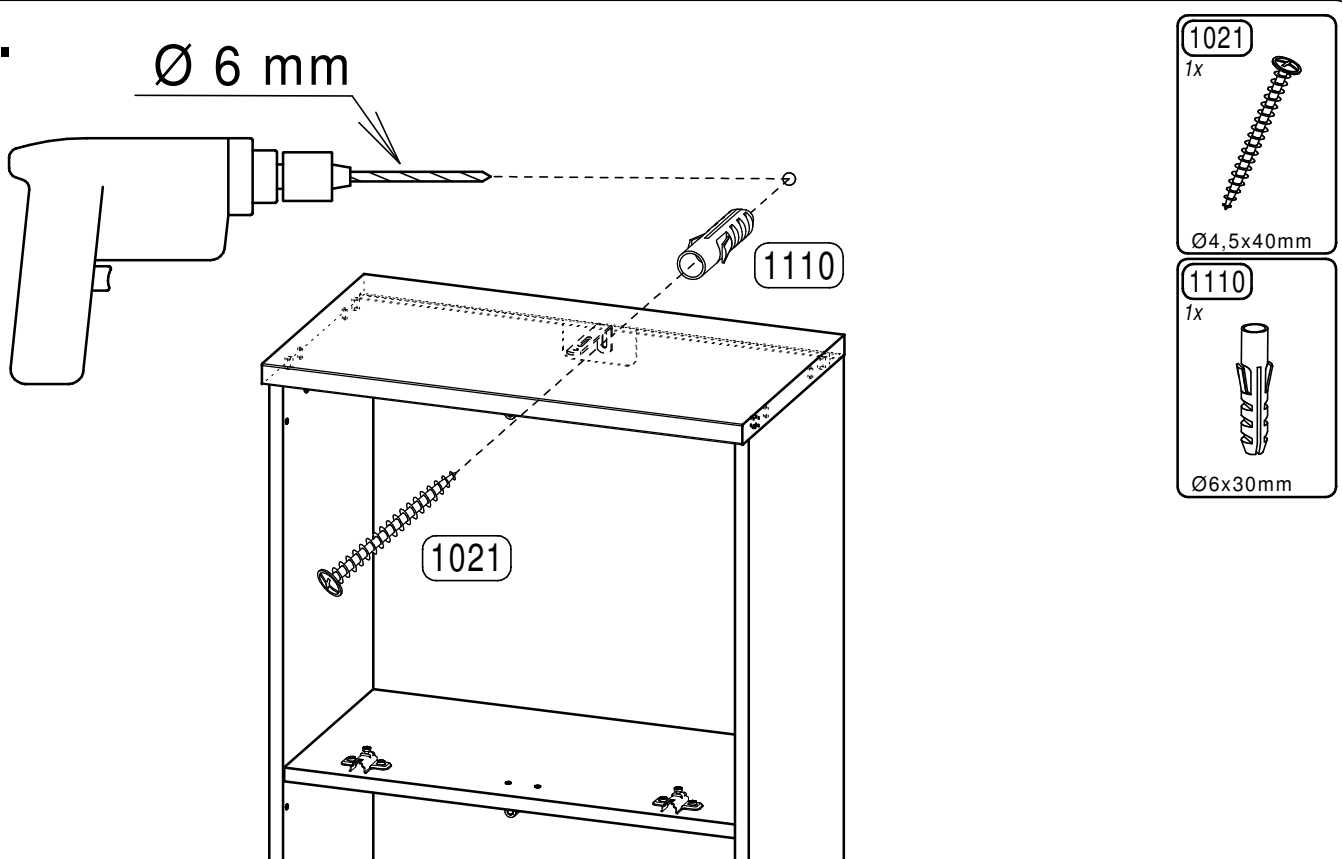

8

erstellt

geändert

geprüft

Datum: 06.11.13

Datum:

Datum: 11.11.13

9.

2 x

5491

9.1

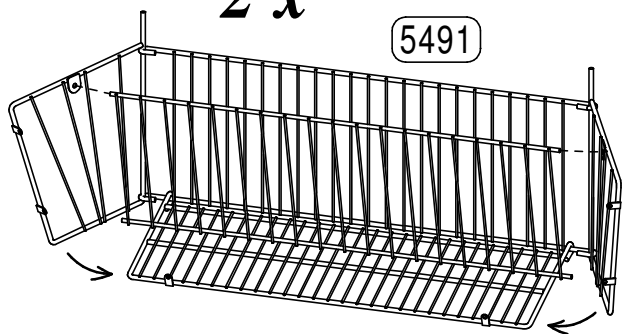

5491

2x

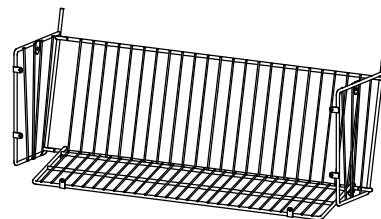

482 x 245 x 260 mm

9.2

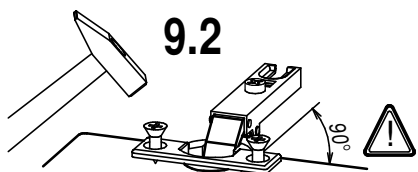

9.3

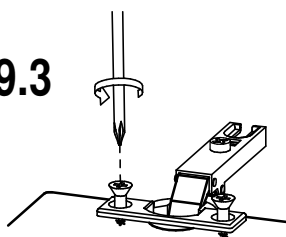

5637

2x



Teilung =
32 mm

1236

4x



Ø6,3x11

1238

12x



Ø6,3x13

4840

9.4

2 x

**Mod. 3263
Mod. 3264**

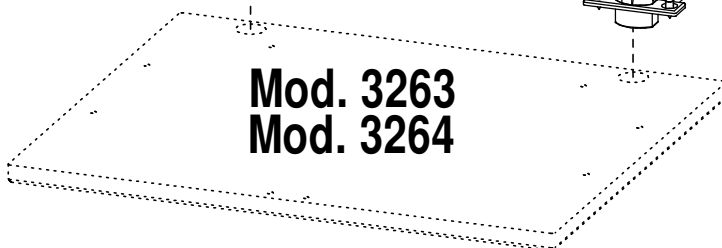

4840

4x

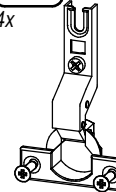

9.5

2 x

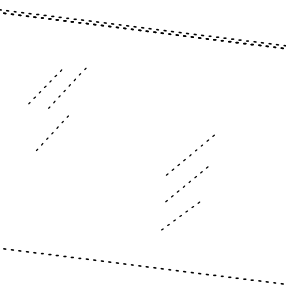
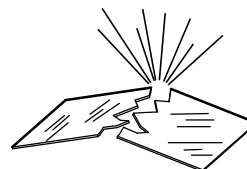
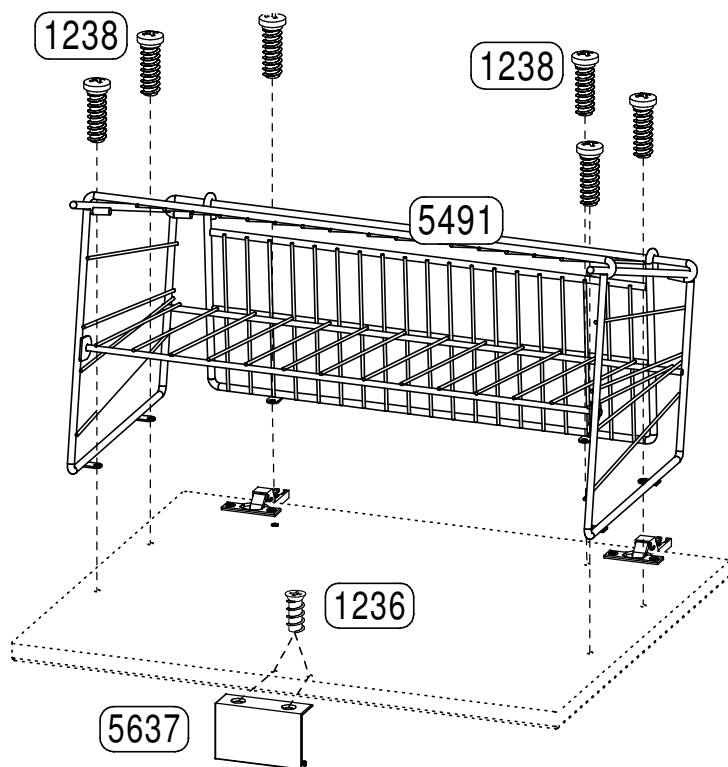

Mod. 3264

9

erstellt

geändert

geprüft

Datum: 06.11.13

Datum:

Datum: 11.11.13

10.

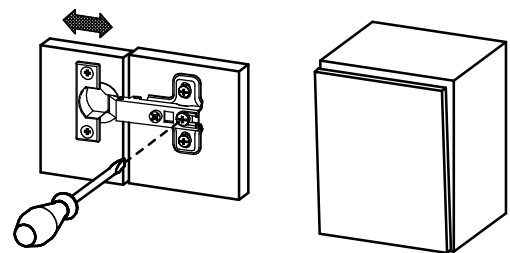
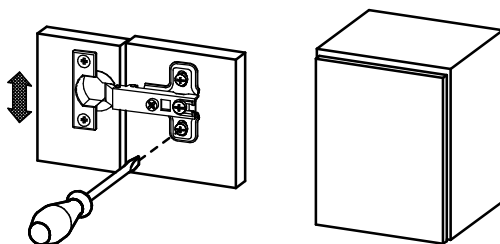
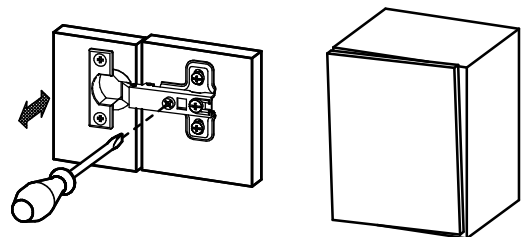
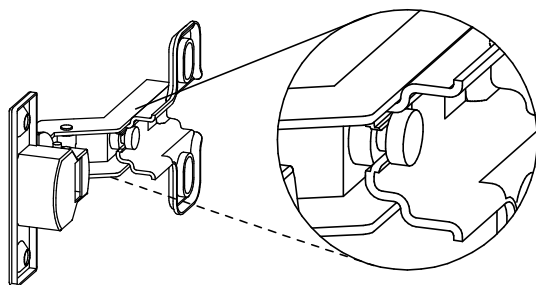
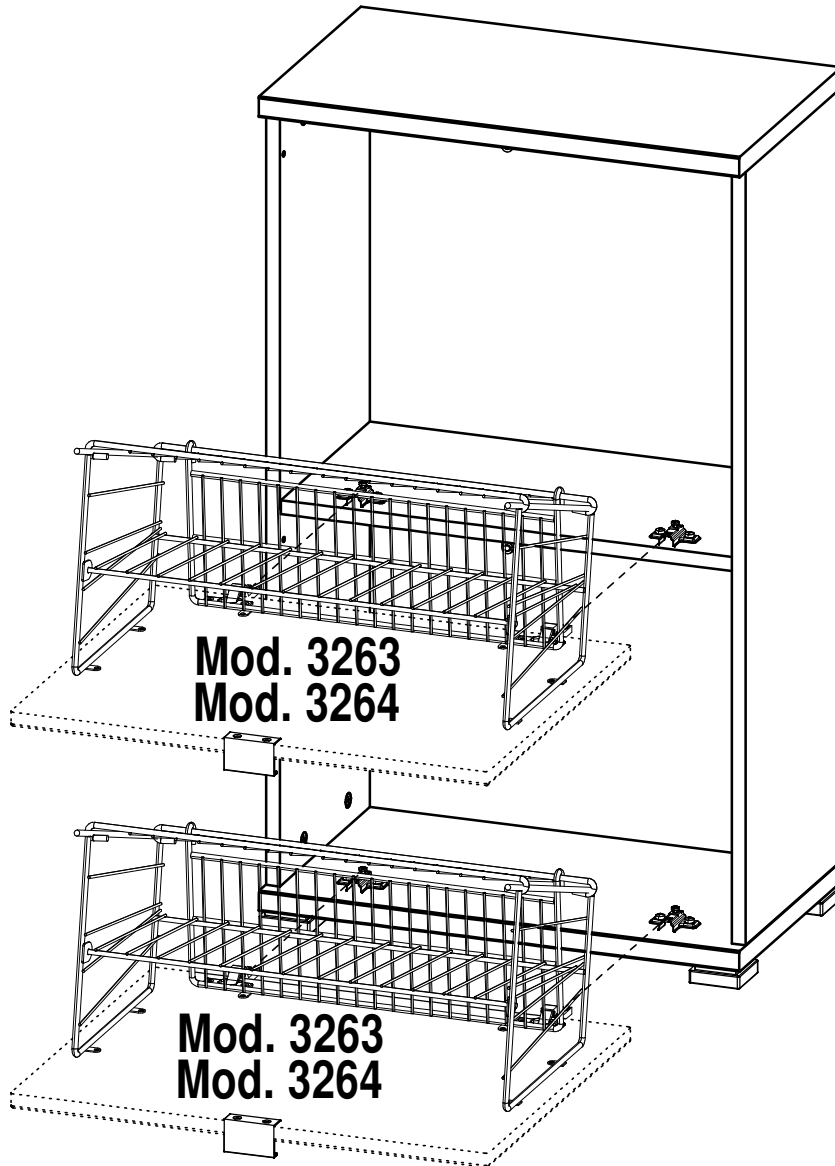

10

erstellt

Datum: 06.11.13

geändert

Datum:

geprüft

Datum: 11.11.13

11.

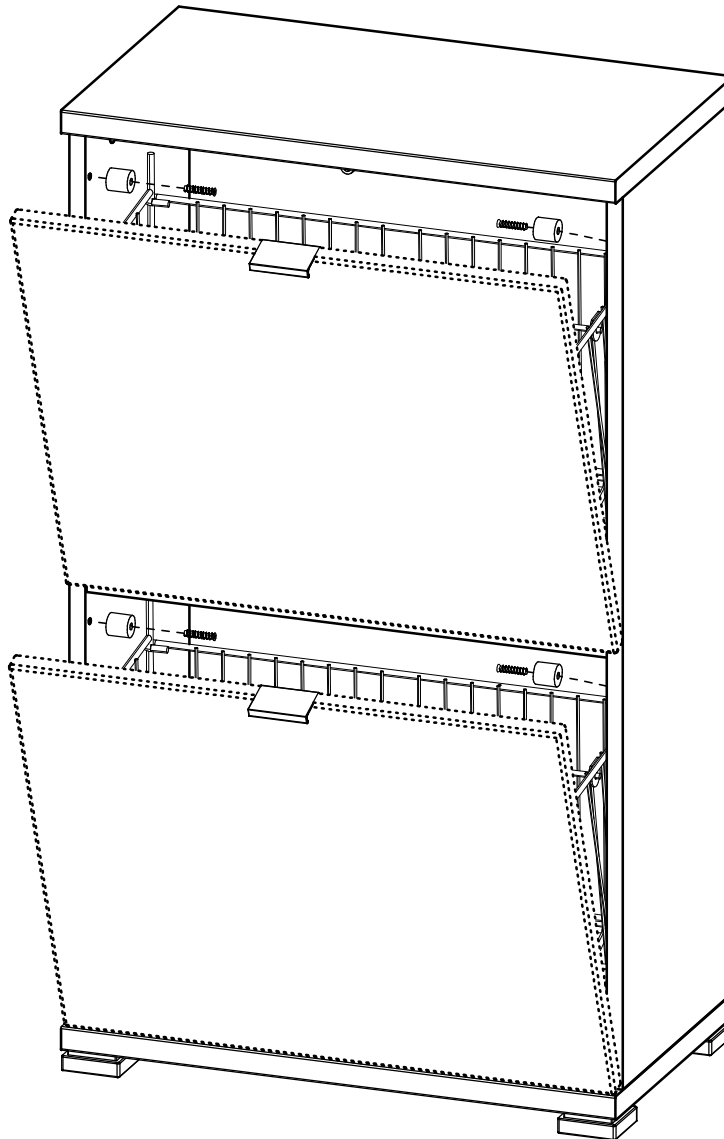
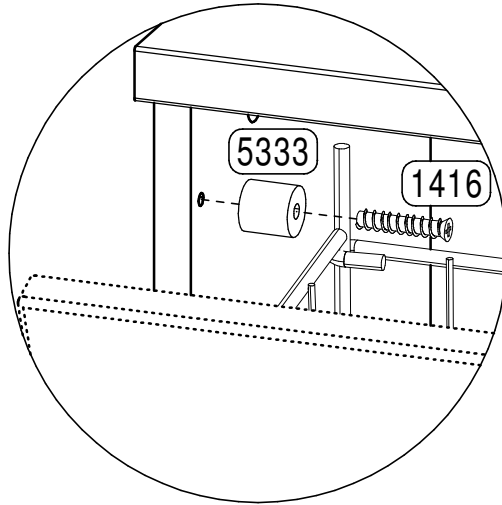
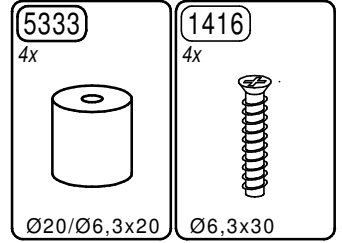

Ersatzteil-Direkt Service

(nur für Deutschland - for germany only - seulement pour Allemagne)

Sehr geehrter Kunde,
 sollte ein Möbelteil bzw. Beschlagteil fehlen oder beschädigt sein, senden Sie uns den Artikel bitte **nicht** zurück, sondern fordern Sie der Einfachheit halber Ersatz direkt bei **GERMANIA** an.
 Tragen Sie Ihren Bedarf in die Tabelle ein und übermitteln Sie uns diese Seite per Post, per Fax, telefonisch oder per e-mail.
 Bitte unbedingt die MODELL-Nr. + DEKOR-Nr. (siehe Karton) und die entsprechende Teilebezeichnung (siehe Teilleiste) angeben.



Mod. Nr.: _____ Dekor-Nr.: _____

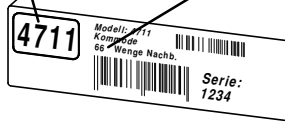

Serie
1234

Möbelteile			
Teil	beschäd.	fehlt	Anzahl
Beispiel Z	X		1

Beschlagteile			
Teil	beschäd.	fehlt	Anzahl
Beispiel 1162	X		2

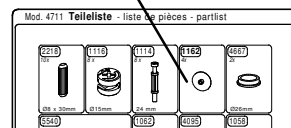
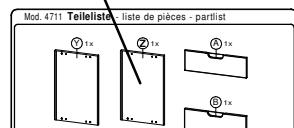

Absender nicht vergessen :

Name:	Strasse u. Nr.:		
PLZ:	Ort :		
Tel.:	Fax:	e-mail:	

Unsere Hotline :

Tel. 05252 84939 und 05252 84962 Fax: 05252 84936

e-mail : service@mygermania.com

GERMANIA - Service - Postfach 1160 D 33189 Schlangen

Sicherheitshinweise



Safety instructions

Indications de sécurité



1.) Montageanleitung aufmerksam durchlesen
 Please read assembly instruction carefully
 Prière de bien lire la notice de montage du début à la fin



2.) Montage nach Montageanleitung durchführen
 Please follow the assembly instruction step by step
 Bien suivre le sens du montage indiqué sur la notice



3.) Montageanleitung aufbewahren
 Please save the assembly instruction
 Bien conserver la notice de montage



ACHTUNG! Beschlagbeutel und Beschlagteile von Säuglingen und Kindern fernhalten

ATTENTION! To avoid suffocation keep plastic bag away from children
 Contains small parts which may be a choking hazard

ATTENTION! Toutes les pièces détachées livrées dans le colis être mis hors de portée des bébés des et enfants



Netzanschluss (230V) nur von einem Fachmann ausführen lassen.
 Sanitäranschluss nur von einem Fachmann ausführen lassen.

Mains connection (230V) has to be done by an expert.
 Sanitary installation has to be done by an expert.

L'électricité (230V) uniquement à faire par un électricien.
 Installation sanitaire à faire par un spécialiste.

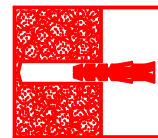

Beiliegendes Befestigungsmaterial eignet sich nur für Massivwände.
 Für andere Wände müssen Spezialdübel verwendet werden.
 Die Festigkeit ist zu Prüfen.

The attached fixing materials is only suitable for solid walls.
 For other Types of walls special dowels have to be used.
 The firmness have to be checked.

Le matériel defixation ci-joint est exclusivement prévu pour des murs pleins(une fixation spéciale est nécessaire pour cloisons placo,..).
 La fermeté est à examiner.

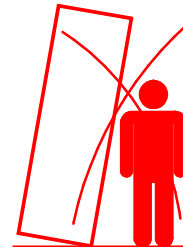

Beiliegende Wandbefestigungen dienen als Kippschutz, unbedingt anbringen!

The attached wall fixing is necessary to avoid tipping and must be fixed!

Les fixations prévues dans le colis préviennent contre le renversement du meuble. Il faut impérativement fixer le meuble au mur, afin d'éviter tout incident!

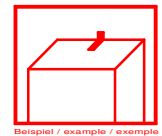

Für Schäden, die durch unsachgemäße Montage entstanden sind, übernehmen wir keine Haftung
For the damages, which have originatet prom improper assembly, we take over no liability.
Pour les dommages qui sont nés par le montage incorrect, nous ne prenons en charge aucune responsabilité.

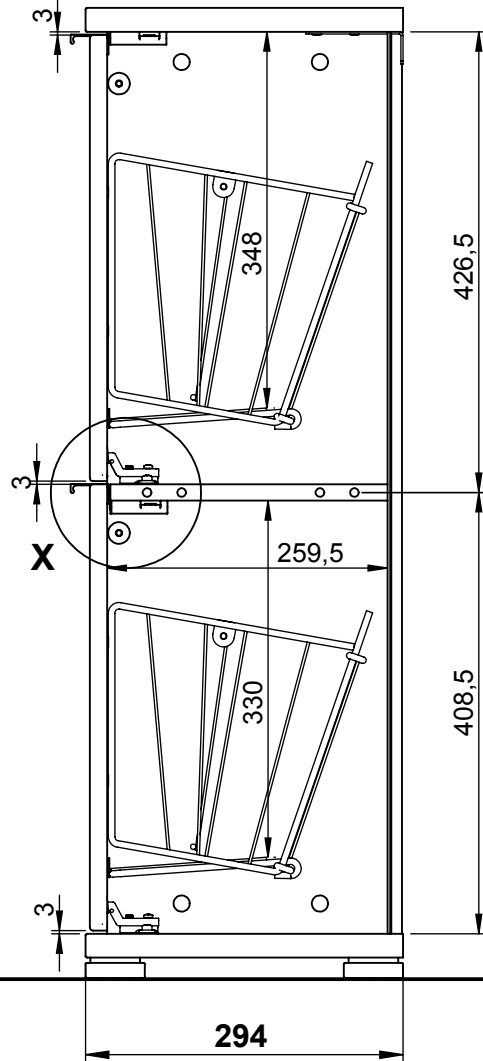
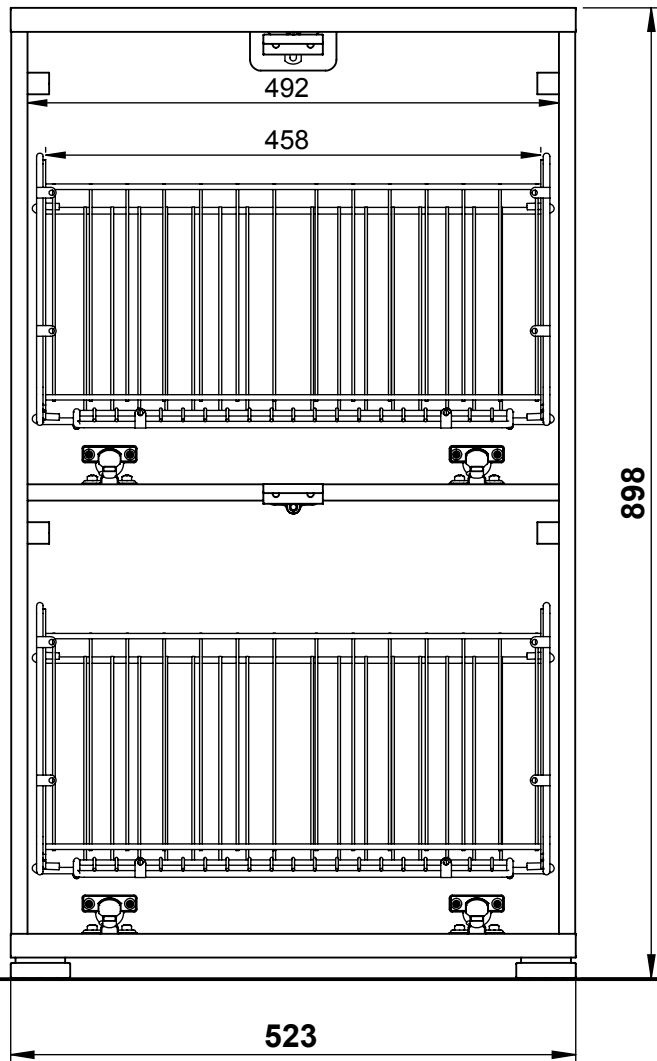

DETAIL X

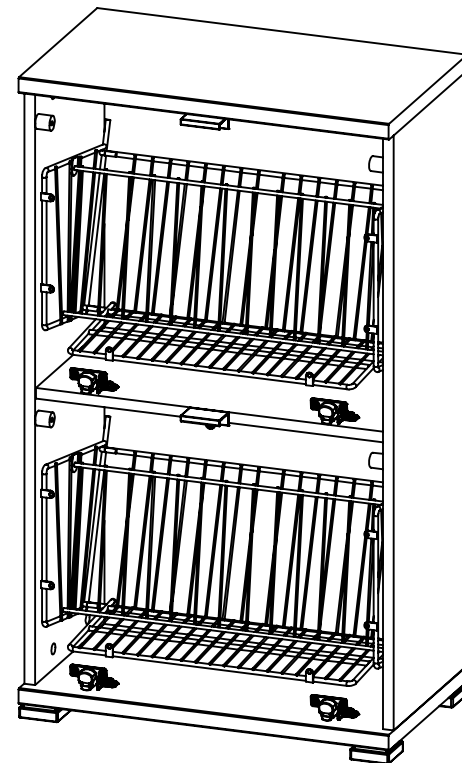
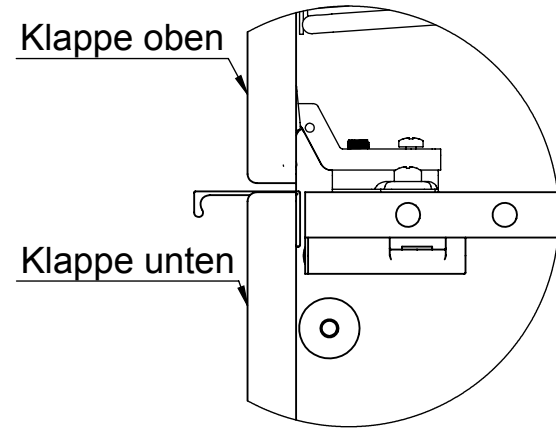

Schuhschrank 3260

Breite: 53 cm
 Höhe: 90 cm
 Tiefe: 30 cm